

CONSULTATION CQFD³

LONOCO[®] 2



Les plans RDC

ech. : 1/100

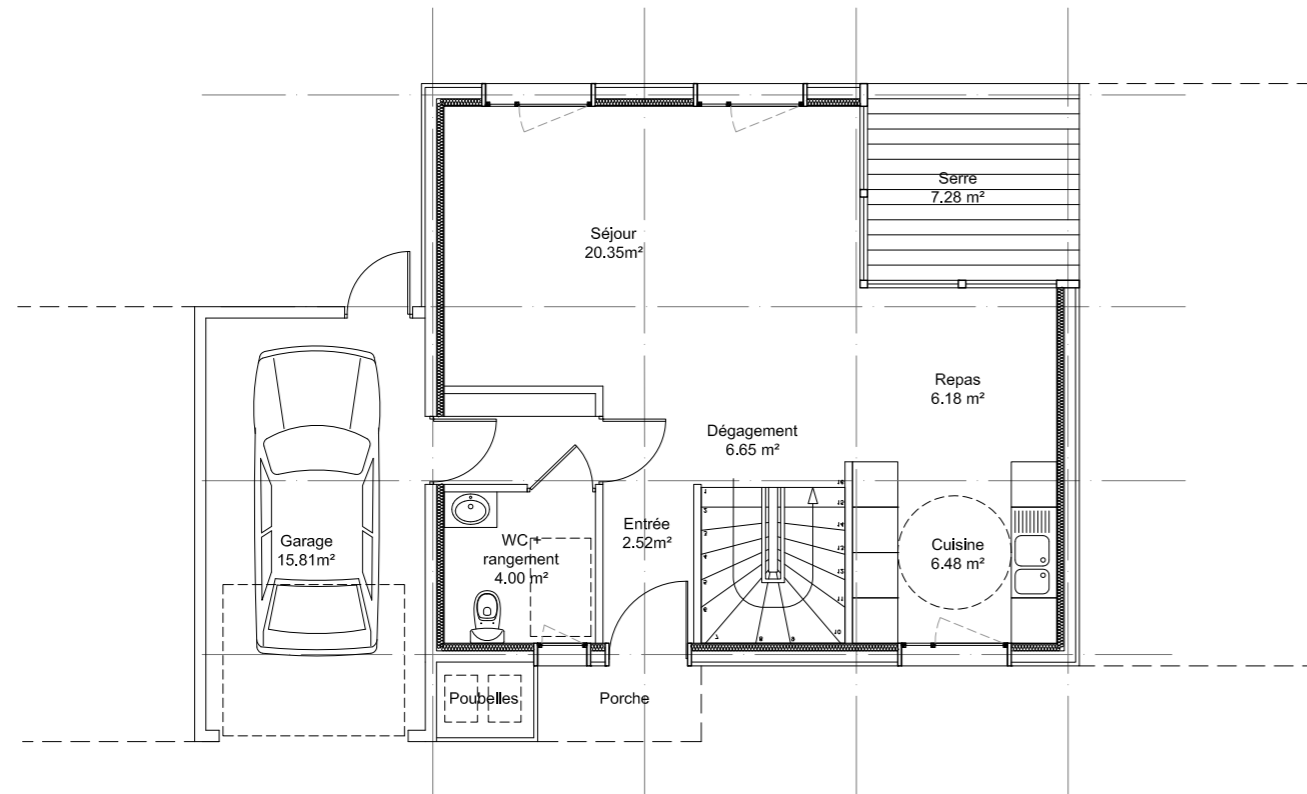

Plan RDC
developpement |X|

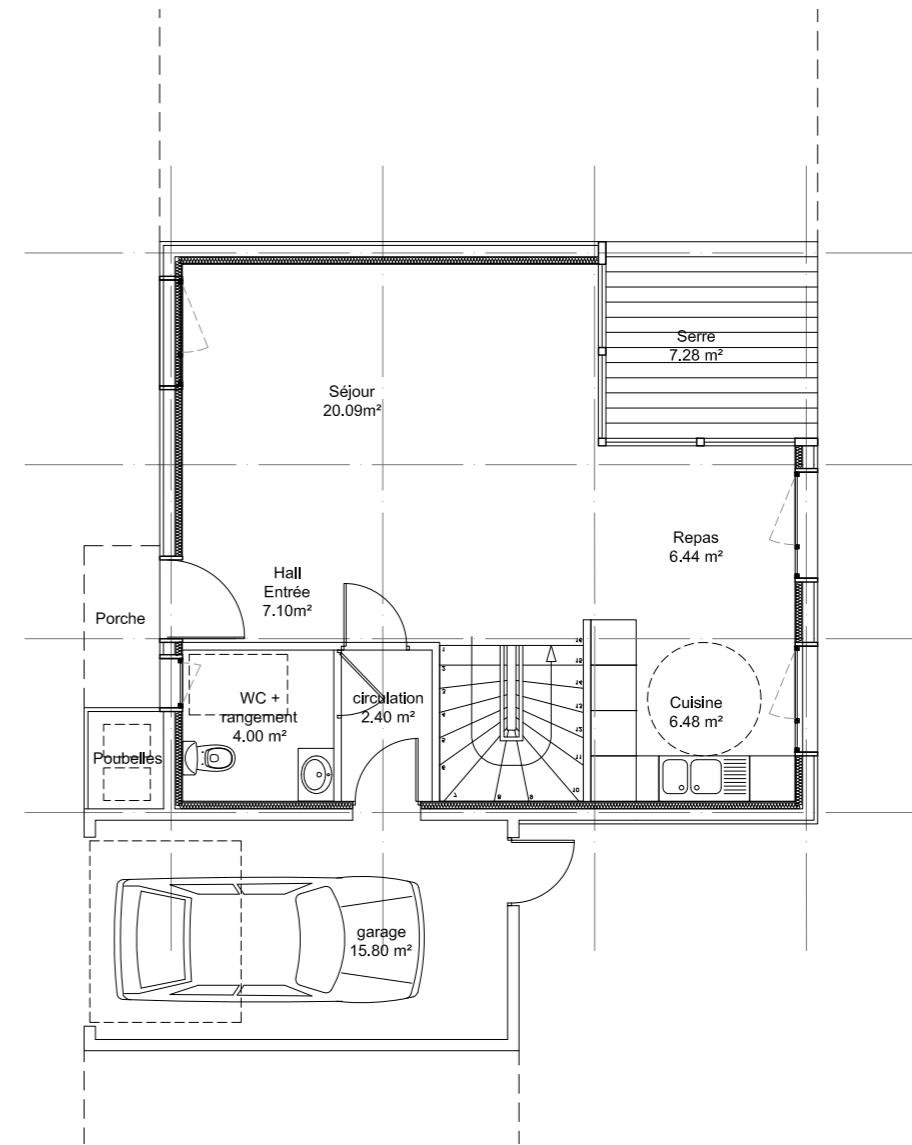

Plan RDC
developpement |Y|

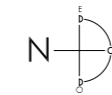

Les plans ETAGES

ech. : 1/100

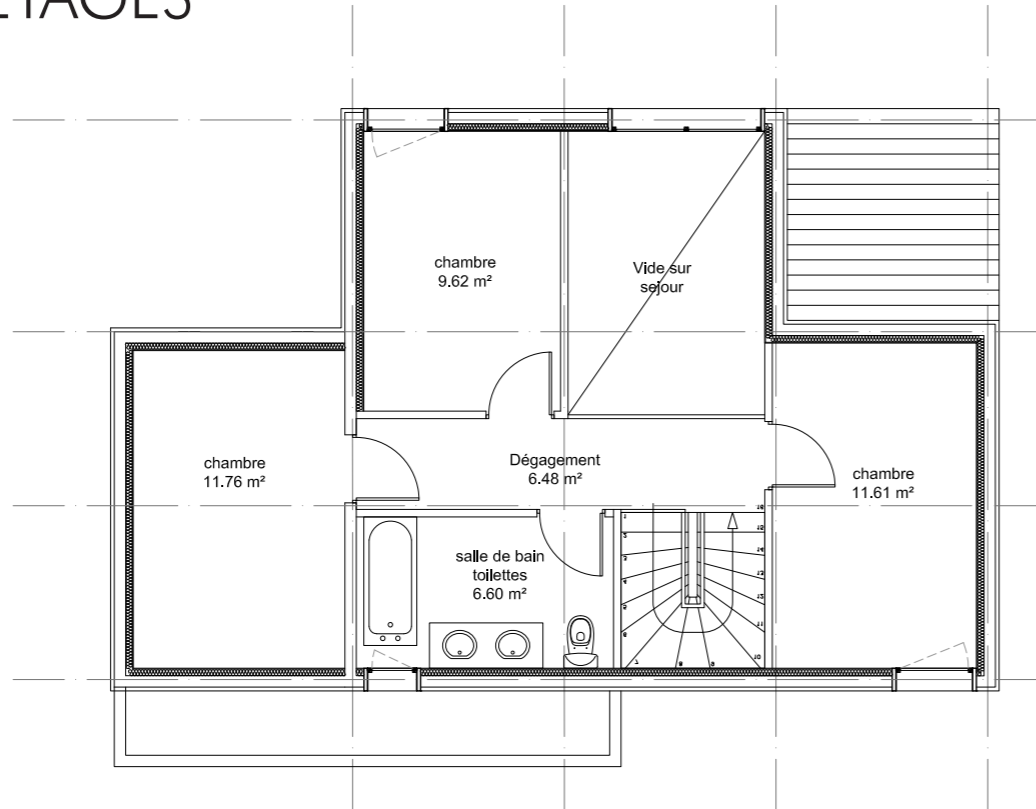

Plan Etage
Type 4 avec garage

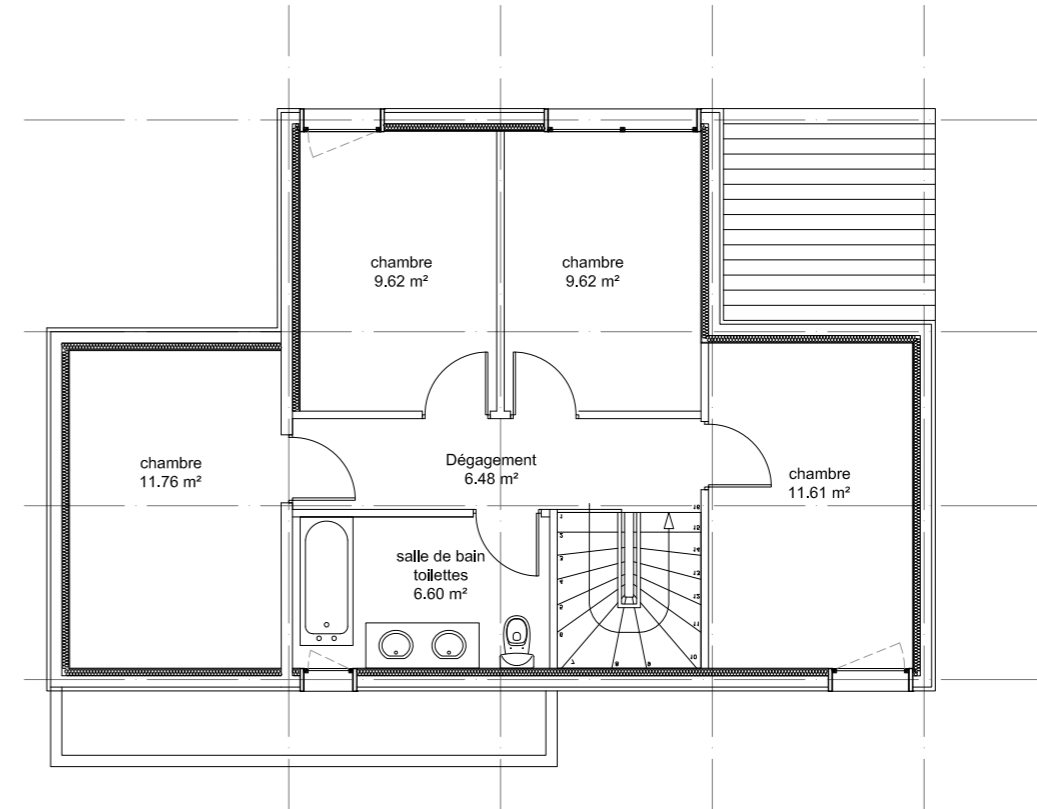

Plan Etage
Type 5 avec garage

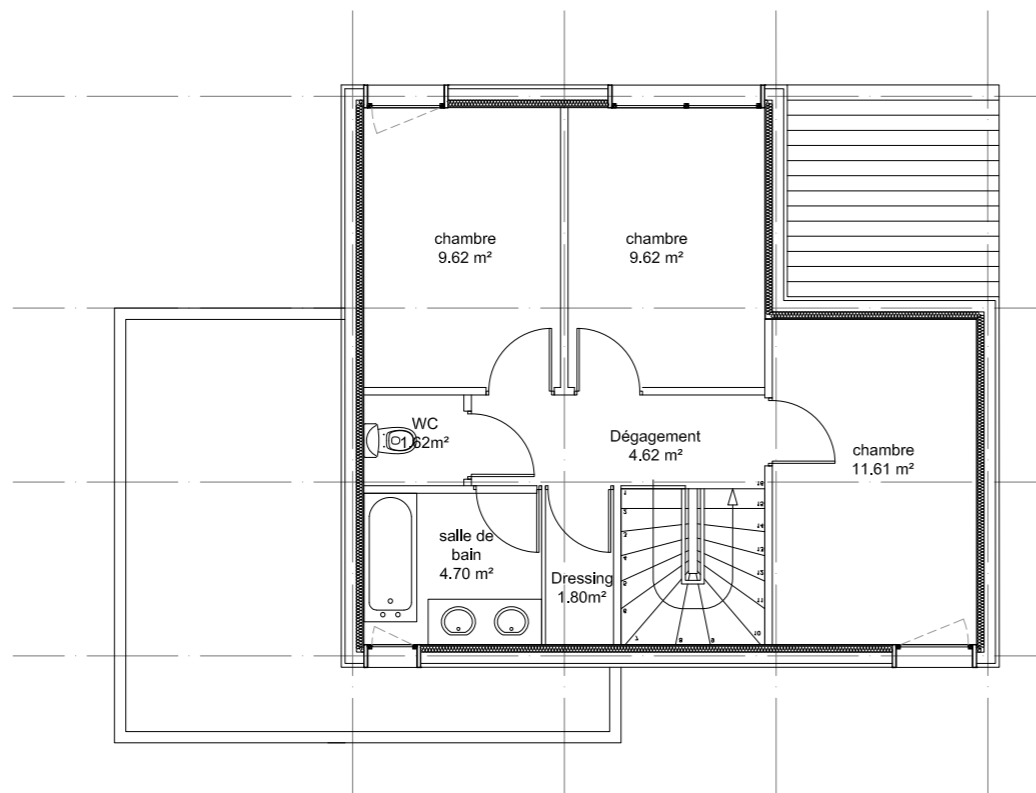

Plan Etage
Type 4

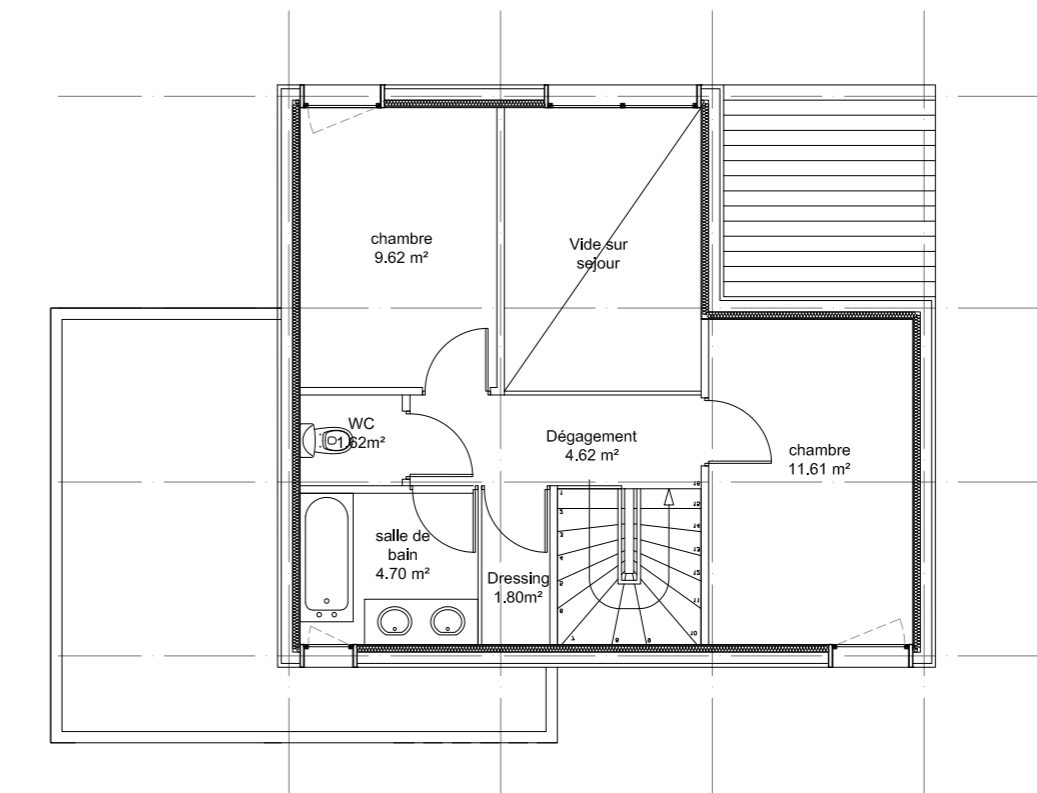

Plan Etage
Type 3

Plan mise en situation developpement |X|Y|Z|



developpement |X|

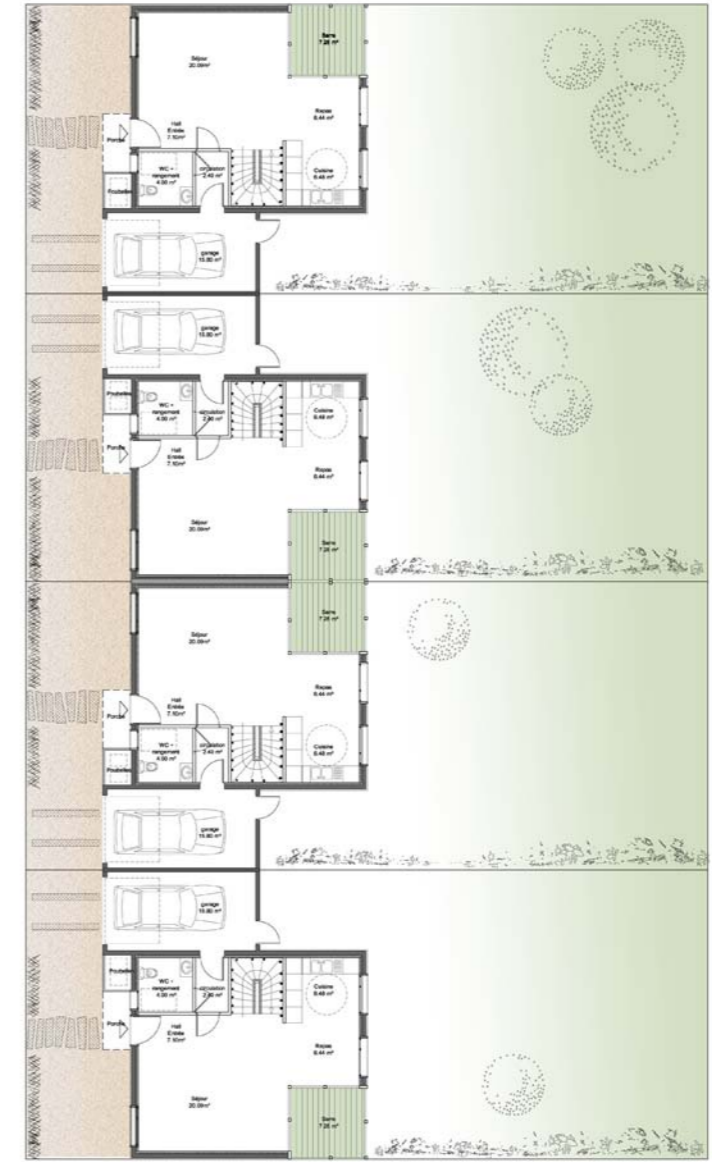

developpement |Y|

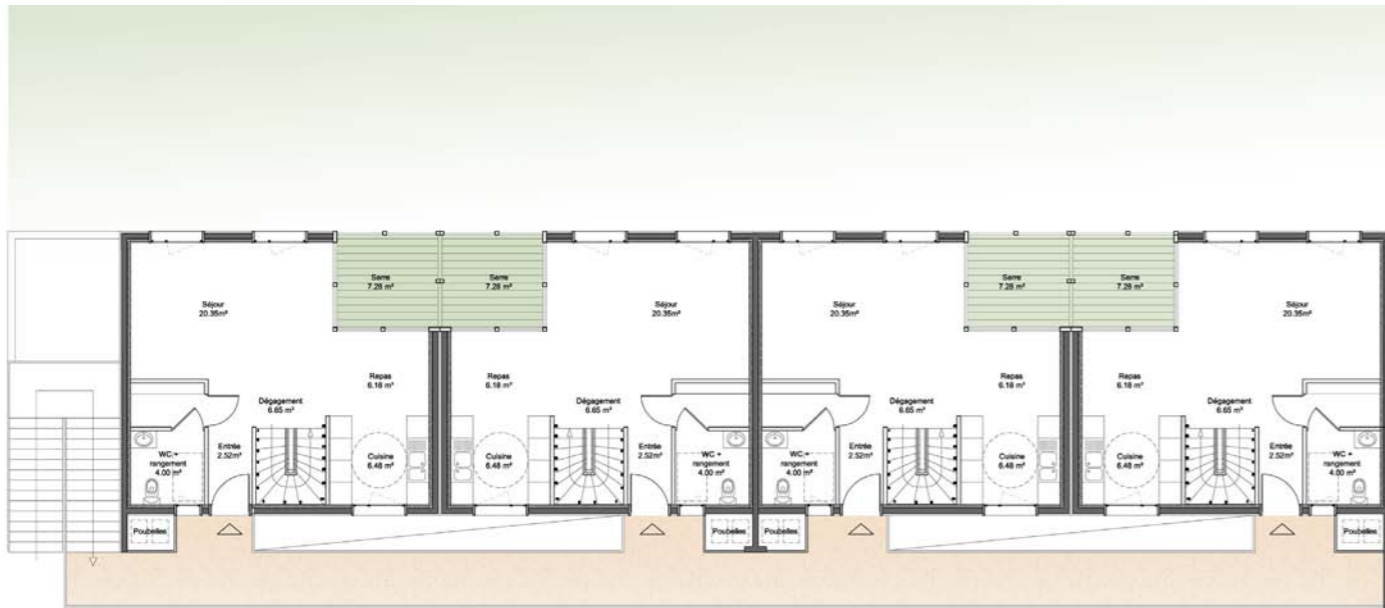

developpement |Z|

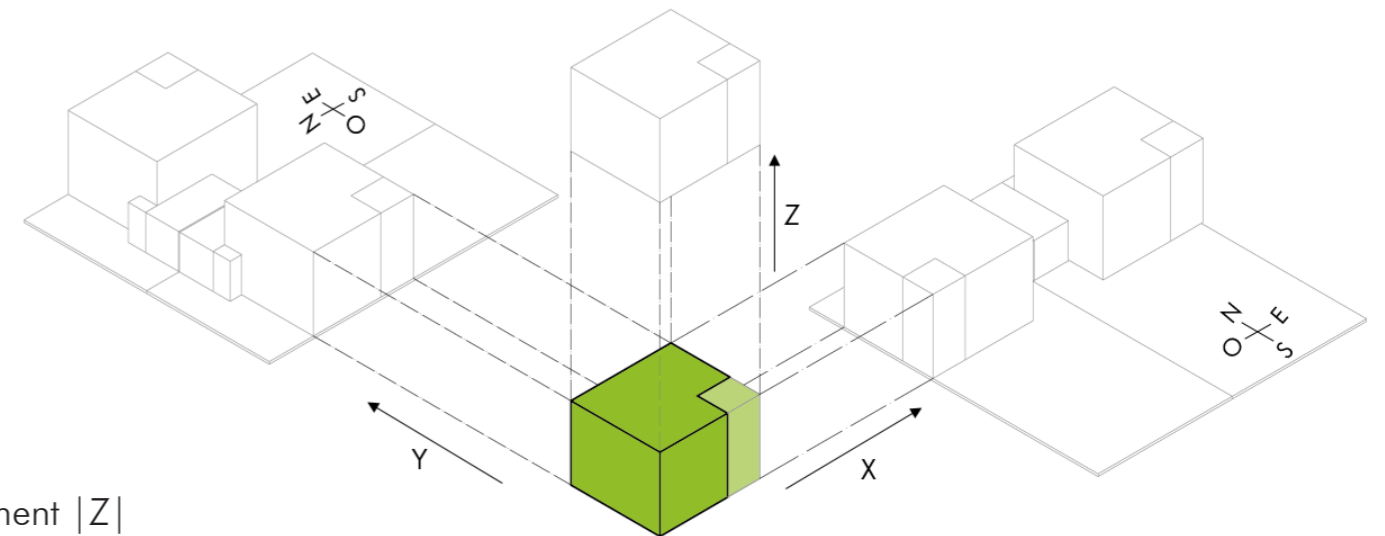

Les typologies

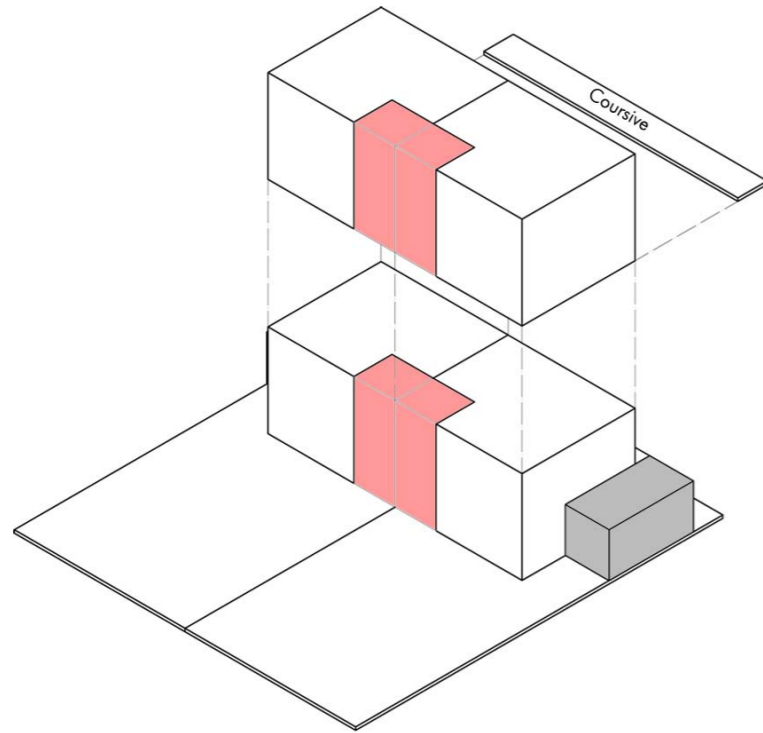

developpement | Z |

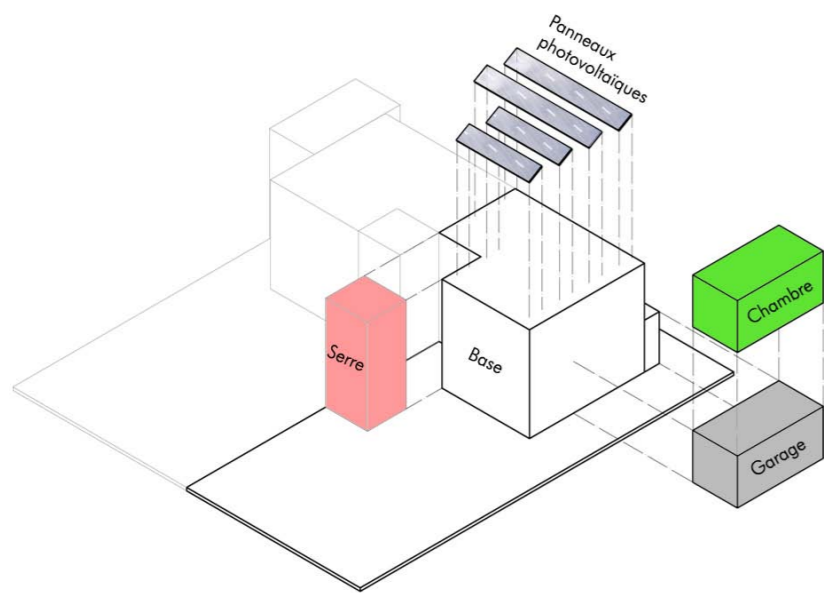

les composantes

BASE	Rez-de-chaussée	Etage
T3 76.15m ² + 7.28m ² serre		
T4 85.77m ² + 7.28m ² serre		

BASE	Rez-de-chaussée	Etage
T3 76.48m ² + 7.28m ² serre		
T4 86.10m ² + 7.28m ² serre		

BASE + GARAGE	Rez-de-chaussée	Etage
T3 76.15m ² + 7.28m ² serre + 15.80m ² garage		
T4 85.77m ² + 7.28m ² serre + 15.80m ² garage		

BASE + GARAGE	Rez-de-chaussée	Etage
T3 76.48m ² + 7.28m ² serre + 15.80m ² garage		
T4 86.10m ² + 7.28m ² serre + 15.80m ² garage		

BASE + GARAGE + CHAMBRE	Rez-de-chaussée	Etage
T4 87.65m ² + 7.28m ² serre + 15.80m ² garage		
T5 97.27m ² + 7.28m ² serre + 15.80m ² garage		

BASE + GARAGE + CHAMBRE	Rez-de-chaussée	Etage
T4 87.98m ² + 7.28m ² serre + 15.80m ² garage		
T5 97.60m ² + 7.28m ² serre + 15.80m ² garage		

Principes bioclimatiques

Architecture

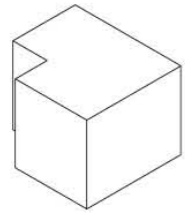

COMPACITE

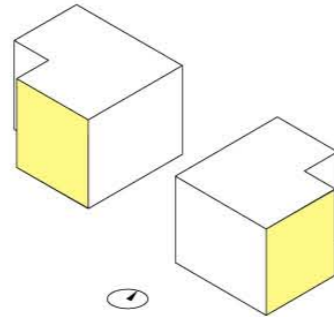

ADAPTATION A
L' ORIENTATION

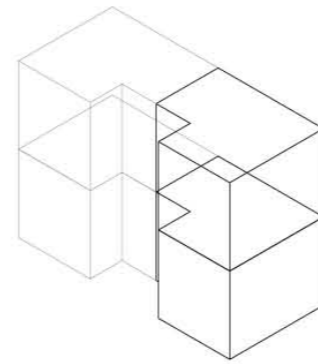

ASSEMBLAGE

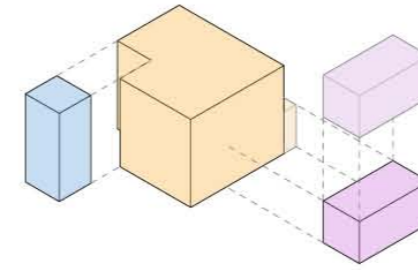

MODULARITE &
STANDARDISATION

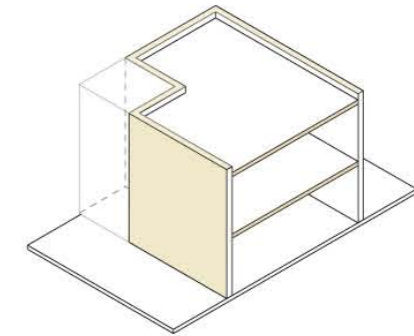

CONSTRUCTION BOIS

Stratégies passives

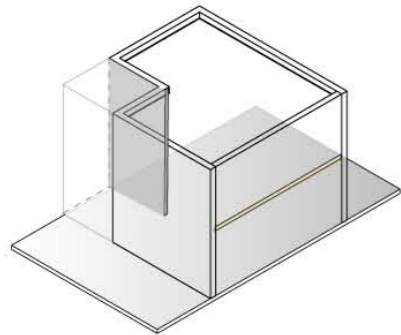

INERTIE
THERMIQUE

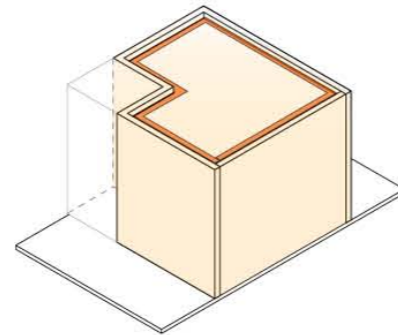

ISOLATION
RENFORCEE

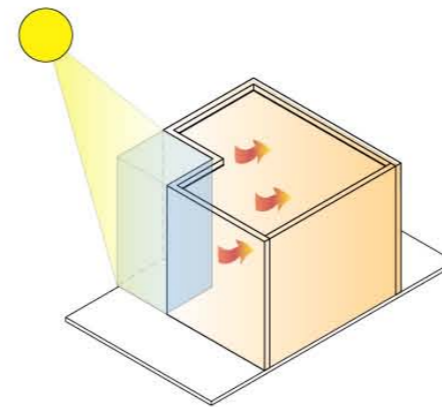

PRE CHAUFFAGE
PASSIF

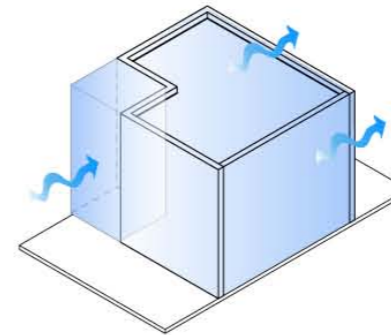

VENTILATION
TRAVERSANTE EN ETE

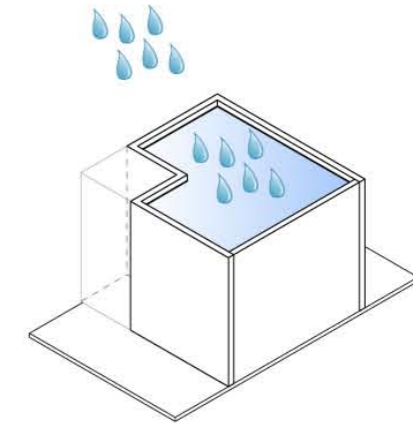

RECUPERATION DES
EAUX PLUVIALES

Systèmes

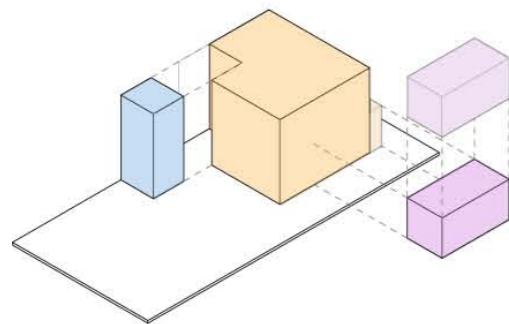

ZONAGE THERMIQUE

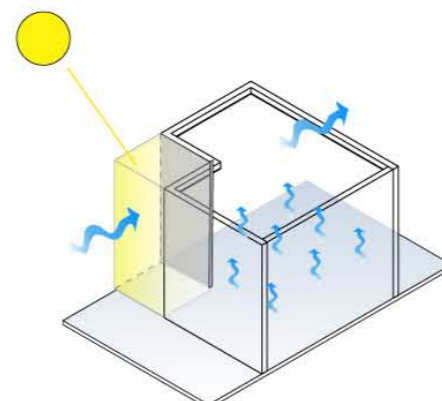

CONFORT D'ETE

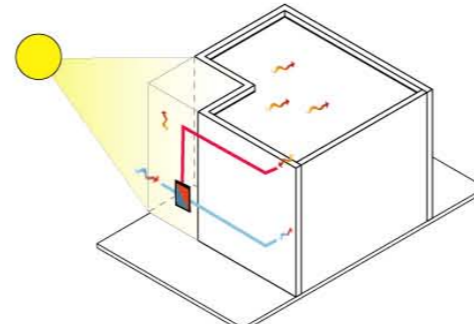

RECUPERATION DE
CHALEUR EN HIVER

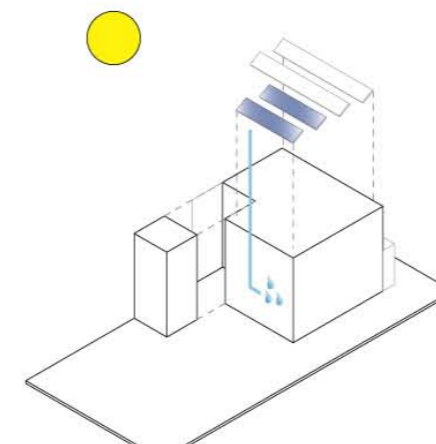

EAU CHAUDE
SOLAIRE

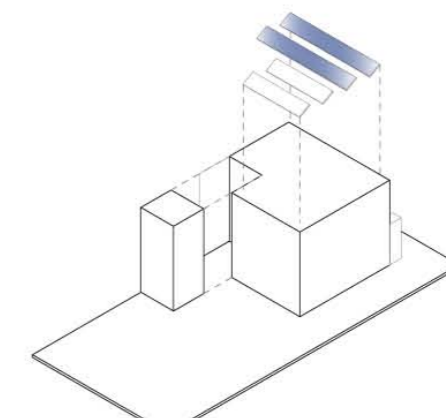

PRODUCTION
D'ENERGIE ELECTRIQUE

Elevations



Elevation Collectif



Elevation maisons en bande

Vue jardin



Vue de la rue sur des maisons en bande



Vue d'un ensemble de logements collectifs

